

*Pastry Chef Resource*

**Spring 2026**

Exceptional Ingredients for Outstanding Results

# *Pastry Chef Resource*

**4376 LB McLeod Road  
Orlando, FL 32811**

## **Office Hours**

**Monday - Thursday: 9:00 AM - 4 PM EST**

**Friday: 9:00 AM - 2 PM EST**

**Phone: 407-730-3157**

**Email: [Order@PastryChefResource.com](mailto:Order@PastryChefResource.com)**

**Fax: 407-536-5033**

## **Delivery**

Deliveries are made between 8:00 AM and 3:00 PM, Monday through Friday. The Greater Orlando area does not have a delivery minimum, however deliveries outside this area may require a minimum order.

To ensure next-day delivery, orders must be submitted by 4:00 PM the prior business day. Please contact our office for your area's specific delivery schedule and minimum requirements.

## **Pick Ups & Walk Ins**

If you are outside our delivery zones or miss your scheduled delivery day, you are welcome to pick up your order at our Orlando warehouse. You can call ahead to place your order or walk-in during business hours. Payment can be made at the time of pickup.

## **Shipping**

For customers outside our delivery zones or the state of Florida, we offer shipping via UPS. Please note that certain items, such as chocolate and frozen products, are not eligible for shipping. Orders can be placed through our office directly or through our website. Shipping charges apply and estimated delivery dates may vary.

## **Returns**

We offer a full money-back guarantee on all products. All returns must be authorized by our management team and our office must be notified within 7 days of the invoice date. Products must be in resellable condition, in their original, unopened packaging, and stored in appropriate conditions until they are picked up.

## **Special Orders**

Please contact our office about any special orders.

## **Pricing**

Please visit our website for pricing, or contact the office.



# Index

<i>Croissants &amp; Pastries</i> .....	1 - 2
<i>Breads, Dinner Rolls &amp; Doughs</i> .....	3
<i>Tart Shells</i> .....	4
<i>Shells, Cones &amp; Puffs</i> .....	5
<i>Layer Cakes</i> .....	6 - 8
<i>Cookies</i> .....	9
<i>Ready to Serve Desserts</i> .....	10
<i>Couvertures &amp; Coatings</i> .....	11
<i>Cocoa Powder, Chips &amp; Spreads</i> .....	12
<i>Chocolate Decor</i> .....	13 - 15
<i>Chocolate Curls &amp; Shavings</i> .....	16
<i>Chocolate Cups &amp; Shells</i> .....	17
<i>Nut Products</i> .....	18
<i>Fillings, Toppings, Glazes &amp; Gels</i> .....	19
<i>Fruit Products</i> .....	20
<i>Flavorings</i> .....	21
<i>Mixes</i> .....	22
<i>Colorings</i> .....	23
<i>Finishing Touches</i> .....	24
<i>Technical Ingredients</i> .....	25
<i>Savory</i> .....	26
<i>Tools</i> .....	27

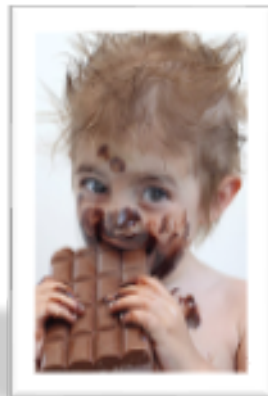



### All Butter Croissants

**B34000:** 80 g - 60 per case

**FB207:** 85 g - 80 per case

**B33241:** 60 g - 70 per case

**B52359:** 40 g - 160 per case

**FB204:** 45 g - 120 per case

**B37761:** 30 g - 195 per case



### Apple Turnover

**B37630:** 105 g - 50 per case

**B32924:** 40 g - 255 per case



### Pain au Chocolate

**B33624:** 70 g - 90 per case (2 barres)

**B59040:** 80 g - 60 per case (3 barres)

**B37762:** 35 g - 210 per case

**FB245:** B35 g - 210 per case



### Avalanche Chocolate

**B52706:** 115 g - 60 per case



### Pain au Raisin

**B40649:** 105 g - 60 per case



### Multi-Grain Croissants

**FB236:** 100 g - 54 per case

**FB234:** 45 g - 120 per case



### Mini Cinnamon Brioche

**B52108:** 45 g - 120 per case



### Almond Croissant

**FB214:** 100 g - 72 per case



### Cinnamon roll

**FB232:** 130 g - 48 per case

**FB247:** 45 g - 200 per case



### Sweet Cheese

**B552415:** 115 g - 60 per case



### Mango Fruit Lattice

**B34082:** 45 g - 100 per case



### Greek Yogurt Cherry

**B52434:** 100 g - 60 per case



### Apple Butter

**B59602:** 115 g - 60 per case



### Fruit Cheese Danish

**B52889:** Strawberry Cheesecake: 100 g - 84 per case

**B52888:** Blueberry Cheesecake: 100 g - 84 per case

**B52976:** Raspberry Cheesecake: 100 g - 84 per case



### Maple Pecan

**B52642:** 90 g - 40 per case

# *Croissants & Pastries cont...*



## **Swiss Fruit Pastry**

**B52923:** Lemon: 36 g - 144 per case

**B52924:** Black Currant: 36 g - 144 per case



## **Mini Gourmandise Assortment**

**B33377:** 140 per case

Mini Chocolate Twist, Mini Cinnamon Swirl, Mini Custard Extravagant, and Mini Cranberry Twist



## **Mini Chocolate Twist**

**B34081:** 30 gr - 100 per case



## **Sliced Croissant Bun**

**B52826:** 70 g - 60 per case



## **Assorted Fruit Paniers Lattice**

**B31507:** 40 g - 100 per case

Apple, Mango, Strawberry, Morello Cherry



## **Plain Bola de Berlim**

**B52928:** 80 gr - 20 per case



## **Spinach Ricotta Savory**

**LCRSPRCL-45:** 85 g - 45 per case



## **Ham and Cheese Savory**

**LCRHCL-45:** 85 g - 45 per case



## **Bacon and Egg Savory**

**LCRBECL-45:** 85 g - 45 per case



## **Spinach Feta Savory**

**B52400:** 110 g - 36 per case



## **Tomato Olive Savory**

**B52399:** 110 g - 36 per case



## **Leek Parmesan Savory**

**B52401:** 110 g - 36 per case

# Breads, Dinner Rolls, and Doughs



**Black Olive & Thyme Fusette**

**B32954:** 45 g - 50 per case



**Classic Baguette**

**BGBL**

20.8" / 10.1 oz - 36 per case



**Petits Pains Finedor**

**B32913:** 45 g - 50 per case



**Green Olive Bread**

**B32915:** 45 g - 45 per case



**Bread with Oat**

**Porridge Sourdough**

**B52825:** 525 g - 16 per case



**Mini Ciabatta Rolls**

**B52347:** 35 g - 200 per case



**Multigrain Roll**

**B60ROMG:** 108 per case



**Carrè Nature Rustique**

**B34921:** 45 g - 200 per case



**Campagne Country Style Rolls**

**B32949:** 45 g - 60 per case



**Assorted Dinner Rolls**

**LM60** - 56 per case

Campagne, Carre Rustique, Petits Pains Finedor, Cereale Recette



**Cereale Recette Dinner Rolls**

**B32916:** 45 g - 60 per case



**Full Croissant Dough Sheets**

**BCRDSHL-10**

5 mm x 280 mm x 380 mm

10 sheets per case



**Raw Danish Swirl**

**FB229B:** 4.1 oz - 60 per case



**Full Danish Dough Sheets**

**BDANDSHL-10**

5 mm x 280 mm x 380 mm

10 sheets per case

# Tart Shells

## ROUND SWEET COATED



- OSY-79024: 4" - 40 per case
- PD307-25: 3.2" - 60 per case
- OSY-198391: 3" - 108 per case
- OSY-78442: 2" - 100 per case
- OSY-78441: 1.5" - 240 per case

## ROUND CHOCOLATE COATED



- OSY-78450: 4" - 40 per case
- PD307-34: 3.2" - 60 per case
- OSY-198921: 3" - 108 per case
- OSY-78449: 2" - 100 per case
- OSY-78448: 1.5" - 100 per case
- PD313-34: 1.5" - 210 per case

## ROUNDSWEET NON-COATED



- PA7205: 3.2" - 72 per case
- PA7200: 1.3" - 288 per case

## SQUARE CHOCOLATE COATED



- PD302-34: 2.7" - 60 per case
- PD312-34: 1.5" - 210 per case

## ROUND FLUTED SWEET



- PD900-47: 8.5" - 10 per case
- PD895-47: 4" - 72 per case
- PA7458: 3.37" - 144 per case

## GRAHAM ROUND COATED



- PD309-97: 4" - 40 per case
- PD307-97: 3.2" - 60 per case
- PD305-97: 2" - 90 per case

## ROUND FLUTED NON-COATED



- HA204: 2.9" - 135 per case
- HA609: 1.9" - 216 per case

## ROUND NEUTRAL COATED



- PD305-04: 2" - 90 per case
- PD316.04: 1.2" - 189 per case

## SQUARE SAVORY NON-COATED



- PA7216: 1.9" - 144 per case
- PA7207: 1.3" - 144 per case

*Délifrance*  
LIVE EVERYDAY DELICIOUS



Since 1967

# Shells, Cones, & Puffs



## Chocolate Cannolis

L072C - 5" - 72 per case  
S200C - 3" - 200 per case



## Cannoli Cream with Chips

PA0200A: Bags - 3 lb  
PA0200: Case - 6 x 3 lb bags



## Cannoli Shells

PA0305: 2.28" - 360 per case  
PA0302: 3.15" - 200 per case  
PA0300: 4.92" - 100 per case



## Medium Eclairs

PA7307: 5" - 140 per case



## Large Baba Savarins

PA7434: 2.5" - 120 per case



## Mini Eclairs

PA7306: 2.25" - 240 per case



## Mini Cream Puff

PD820-50: 1.5" - 250 per case



## Large Cream Horn

PD630-38: 4.75" - 56 per case



## Large Cream Puff

PD835-50: 3.5" - 80 per case



## Small Bouchees (Vol au Vents)

PA7304 - 1.5" - 336 per case



## Small Cream Horn

PA7303: 2.14" - 297 per case



## Large Bouchees (Vol au Vents)

PA7425 - 3.2" - 72 per case

# Layer Cakes



## Opera

4" x 12"

**SYM125**

4 strips per case

**SY125CT72**

72 pieces per case

Three layers of thin almond sponge soaked with espresso. Filled with ganache and coffee butter cream.



## Dublin

4" x 12"

**SYM246**

2 strips per case

**SY246CT72**

72 pieces per case

Layers of dark chocolate sponge soaked with Guinness beer syrup, filled with three layers of bittersweet chocolate ganache, topped with chocolate mirror glaze.



## Black Forest Cheesecake

4" x 12"

**SYM241**

2 strips per case

**SY241CT72**

72 pieces per case

Creamy New York style cheesecake topped with bitter chocolate mousse with poached cherries and chocolate shavings



## Marjolaine

4" x 12"

**SYM164**

2 strips per case

**SY164CT72**

72 pieces per case

Four layers of hazelnut daquoise filled vanilla mousse, praline mousse and chocolate mousse.



**SY164CT96** \*limited stock

96 pieces per case



## Tiramisu

4" x 12"

**SYM146**

2 strips per case

**SY146CT72**

72 pieces per case

Ladyfingers soaked in coffee liquor filled with a delicious mascarpone mousse.

# Layer Cakes



## Red Velvet

4" x 12"

**SYM170**

2 strips per case

**SY170CT72**

72 pieces per case

Three layers of red chocolate sponge brushed with vanilla syrup, and three layers of creamy white cream cheese.



## Equator

4" x 12"

**SYM157**

2 strips per case

**SY157CT72**

72 pieces per case

Raspberry passion fruit coulis, coconut biscuit. Topped with passion fruit glaze.



## Edelweiss

4" x 12"

**SYM162**

2 strips per case

**SY162CT72**

72 pieces per case

Vanilla biscuit, raspberry coulis, white chocolate mousse and a crunchy hazelnut praline. Topped with raspberry glaze.



## Sunrise

4" x 12"

**SYM333**

2 strips per case

**SY333CT72**

72 pieces per case

Coconut Mousse, with passion fruit coulis, two layers of almond dacquoise



## My Love

4" x 12"

**SYM331**

2 strips per case

**SY331CT72**

72 pieces per case

Vanilla mousse, raspberry coulis, and three layers of almond dacquoise

# Layer Cakes



## Carrot Cake

4" x 12"

**SYM163**

2 strips per case

**SY163CT72**

72 pieces per case

Three layers of moist carrot cake, creamy cream cheese icing, topped with semi-candied shredded carrots strip cake.



## Italian Lemon Torte

4" x 12"

**SYM189**

2 strips per case

**SY189CT72**

72 pieces per case

Ladyfinger cake soaked with lemon syrup, lemon curd, white chocolate mousse, and a white chocolate crunch bottom.



## Primavera *\*limited stock*

4" x 12"

**SYM143**

2 strips per case

**SY143CT72**

72 pieces per case

Strawberry and pistachio mousse between layers of vanilla sponge.



## Hazelnut *\*limited stock*

4" x 12"

**SYM145**

2 strips per case

**SY145CT72**

72 pieces per case

3 layers of hazelnut mousse alternating with 3 layers of chocolate sponge cake.



## Raspberry White Chocolate Mousse

4" x 12"

**SYM708**

2 strips per case

Red velvet cake, ladyfinger cake, filled with white chocolate mousse and raspberry jam, topped with raspberry mirror glaze.

# Cookies



## Madeleines

**OS41042:** 45 g - 70 per case  
**OS24078:** 18 g - 140 per case



## Pizzelle Vanilla

**VDP-36:** 5 trays per case



## Ladyfingers

**PA2500:** 300 per case



## Rolled Wafer Cookies

**BON802:** 280 per case



## Shortbread Cookies

**SS1002:** 2" x 2" - 220 per case



## Vegan Gourmet Cookies - 2 oz

**SS1010:** Vegan Chocolate Chip - 140 per case  
**SS1011:** Vegan Banana Oatmeal - 140 per case  
**SS1012:** Vegan Peanut Butter - 140 per case



## Artisan Gourmet Cookies

*Ready to Bake All Butter Cookies 3 oz - 96 per case*

- SS1003:** Oatmeal Raisin
- SS1004:** Chocolate Cookie with Chocolate chips
- SS1005:** Key Lime White Chocolate Chips
- SS1006:** Macadamia White Chocolate Chip
- SS1007:** Orange Chocolate Chip
- SS1008:** Peanut Butter
- SS1009:** Chocolate Chip

*(Give us your recipe and we can make it!)*

## Individually Wrapped Cookies

*Made fresh to order - 5 day lead time  
40 cookies per case*

- SS1013:** Chocolate Chip
- SS1014:** Chocolate Cookie with Chocolate Chips
- SS1015:** Oatmeal Cranberry Walnut
- SS1016:** Macadamia Nut with White Chocolate Chips
- SS1017:** Matcha with White Chocolate Chips and Almonds

# Ready to Serve Desserts



## Hollywood Bon Bon

**NOE780:** 192 per case

Lime Dome, Banana Caramel Dome,  
Mango-Passionfruit Dome and Raspberry  
Dome



## Noel Truffles

**NOE728:** 7 oz

7 oz box / approximately 20 per box



## Parisien Macaron - 1.5"

**BON300:** 192 per case

Dark Chocolate, White Chocolate,  
Raspberry, Apricot, Lemon Poppy Seed,  
and Pistachio



## Classic Neutral Crepes

**OS7073:** 13" - 75 per case



## Palmiers (Elephant Ears)

**OSNPR99NA19:** 65 g - 80 per case

**OSNPR99N19:** 20 g - 200 per case



## Churros

**RD6037:** 10" - 50 per case



**Duomo Gelato™**



## Gelatos and Sorbets

**Made Fresh To Order, 4 Day Lead Time**  
**Full Flavor List Available Upon Request**

Vanilla Bean Gelato: **DG1061** - 2 x 5 L

Chocolate Gelato: **DG1016** - 2 x 5 L

Strawberry Gelato: **DG1057** - 2 x 5 L

White Chocolate Raspberry Gelato: **DG1065** - 2 x 5 L

Dulce De Leche Gelato: **DG1025** - 2 x 5 L

100% Puro Pistachio Gelato: **DG1050** - 2 x 5 L

Mixed Berry Gelato: **DG1027** - 2 x 5 L

Lemon Gelato: **DG1034** - 2 x 5 L

Blood Orange Gelato: **DG1070** - 2 x 5 L

Lemon Sorbet: **DG1077** - 2 x 5 L

Raspberry Sorbet: **DG1090** - 2 x 5 L

Mango Sorbet: **DG1079** - 2 x 5 L

Passionfruit Sorbet: **DG1085** - 2 x 5 L



# Couvertures & Coatings



## Dark Couvertures

**CB64587:** Guayaquil 64% - 11 lbs

**VAL269:** Equatorial 55% - 6.6 lbs

**VAL266:** Caraibes 66% - 6.6 lbs

**NOE013:** Noel Dark 61% - 22 lbs

**CB811NV0595:** 811 NV Dark 54.5% - 22 lbs

**PS4009488:** Belcolade 54% - 33lbs

**CB58587:** Mi Amere 58% - 11 lbs

**VAL273:** Manjari 64% - 6.6 lbs

**VAL265:** Guanaja 70% - 6.6 lbs

**PS4009489:** Belcolade 59% - 33 lbs

**PS4017004:** Belcolade 60% - 33 lbs

**PS4009775:** Belcolade 55% - 11 lbs

NEW

**NE41170:** Blanxart Horta 55% - 11 lbs

NEW

**NE41171:** Blanxart Gracia 62% - 11 lbs

## Milk Couvertures

**CB35587:** Lactee Barry 35.3% - 11 lbs

**CB35538:** Lactee Superieure 38% - 11 lbs

**NOE010:** Noel Milk 36.8% - 22 lbs

**CB823NV-595:** 823 Milk 33.6% - 22 lbs

**VAL296:** Jivara 40% - 6.6 lbs

**VAL272:** Caramelia 36% - 6.6 lbs

**PS4006961:** Belcolade 34% - 11 lbs

NEW

**NE41270:** Blanxart Sants 34% - 11lbs

## White Couvertures

**CB29587:** Blanc Satin 29.2% - 11 lbs

**NOE916:** Noel White 30% - 22lbs

**CBW2-US-U76:** W2 White 28% - 5.5 lbs and 22 lbs

NEW

**NE41370:** Blanxart Born 28% - 11 lbs

**VAL304:** Dulcey Blond 35% - 6.6 lbs

**VAL271:** Ivoire 35% - 6.6 lbs

**PS4010727:** Belcolade 30% - 11 lbs

## Coatings

### Chocolate Coatings

**CB111:** Dark Prima Coating - 11 lb block

**CBBR656:** Callebaut Pâte à Glace Brune - 5 kg

**CBBV656:** Callebaut Pâte à Glace Ivoire - 5 kg

**NOE657:** Noel Pâte à Glace Brune - 22 lbs

**NOE643:** Noel Pâte à Glace Ivoire - 22 lbs



### Compound Coatings

**PS4008389:** Carat Milk Coverlux - 25 lbs

**PS4007938:** Carat White Coverlux - 25 lbs

**PS4010327:** Carat Dark Coverlux - 25 lbs

**PS4008161:** Decorcrem Dark - 10 lbs

**PS4019688:** Decorcrem White - 10 lbs

NEW

**NE42162:** Zafiro Cocoa Dark - 11 lbs

NEW

**NE42209:** Zafiro Milk - 11 lbs

NEW

**NE42319:** Zafiro Blanca - 13 lbs

NEW

**NE42602:** Zafiro Pistachio - 13 lbs

**CB3155:** 100% Grand Caraque - 3 kg



# Cocoa Powder, Chips & Spreads

## Cocoa Powder

- CB54722:** 22/24% Bendsorp - 50 lbs
- CB760A:** 22/24% Extra Brut Each - 2.2 lbs
- CB760:** 22/24% Extra Brut Case - 6 x 2.2 lb bags
- NOE972:** 10/12% Black Noel Cocoa Powder - 3 lbs
- NOE971:** 22/24% Noel Cocoa Powder Garnet - 8 lbs

## Fillings

- CBX32:** Cara Crakine - 11 lbs

## Cocoa Butters

- CB3654:** 100% Pure Cocoa Butter - 6.6 lbs
- CB7065:** Mycryo Cocoa Butter Powder - 550 g



## Chips, Chunks and Batons



- CB301:** 600 Count Semisweet Chunks - 22 lbs
- CB328:** 1,000 Semisweet Count Chips - 22 lbs
- CB329:** 4,000 Semisweet Count Chips - 22 lbs
- CB317:** 10,000 Semisweet Count Chips - 44 lbs
- NOE204A:** Chocolate Batons Box - 300 count
- NOE204:** Chocolate Batons Case - 15 boxes



- CB601016:** 600 Count White Chunks - 30 lbs
- CB610015:** 1,000 Count White Chips - 22 lbs
- CB602036:** 4,000 Count White Chips - 22 lbs
- CB611040:** 10,000 Count White Chips - 30 lbs



## Ganache

- NE44309:** Sacher Supreme Ganache - 13 lbs
- NE44313:** Sacher Milk Ganache - 13 lbs
- NE44318:** Sacher Bianca Ganache - 13 lbs
- PS4107194:** Non Hydro Ganache - 20 lbs



## Spreads

- NE290021:** Vela Cookies & Cream - 13 lbs
- NE44128:** Vela Nocciola Spread - 13 lbs
- NE44150:** Vela Bianca Sprad - 13 lbs
- NE44251:** Vela Gold Spread - 13 lbs
- NU9000:** Nutella Bucket - 6.6 lbs
- NU9003A:** Nutella Piping Bag - 2.2 lbs
- NU9003:** Nutella Piping Bag Case - 6 x 2.2 lb bags



# Chocolate Decor



**1.46" Twister**

DBL96269: 3150 per tray



**8" Dark/White Spear**

DBL91170: 2 x 245 per tray



**8" Panatella Duo**

DBL93176: 110 per tray

**8" Panatella Dark**

DBL91171: 110 per tray

**8" Panatella White**

DBL93171: 110 per tray



**4" Mikado Dark**

DBL91162: 355 per tray

**4" Mikado White**

DBL93165: 355 per tray



**4" Mikado Dark/White**

DBL72109: 355 per tray



**Green Twist**

DBL77471: 80 per tray



**Turitella**

DBL72110: 117 per tray



**Tramontana Marbled**

DBL92102: 131 per tray



**Tornado White/Dark**

DBL93208: 144 per tray



**Happy Birthday**

DBL91019: 140 per tray



**Blizzard Assortment**

DBL93197: 262 per tray

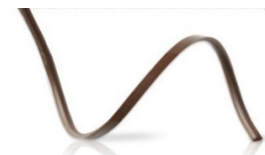

**Dark Spiral**

DBL97145: 80 per tray



**Diablo Dark/White**

DBL73227: 290 per tray



**Exclusive Assortment**

DBL71202: 310 per tray



**Diablo Spring**

DBL78229: 290 per tray

# Chocolate Decor cont...



**Domino White/Pink**

DBL73219: 500 per tray



**Domino White/Dark**

DBL7701: 500 per tray



**Filigran Fan**

NOE820: 245 per tray



**Rose Dark/White**

DBL92183: 180 per tray



**Rose White/Dark**

DBL92182: 180 per tray



**Dark Filigran Feathers**

NOE822: 280 per tray



**Daisy XL**

DBL78324: 108 per tray



**Daisy Mini**

DBL77555: 140 per tray



**Chocolate Lime Slice**

DBL23515: 168 per tray



**Elegance Milk Feather**

DBL97140: 160 per tray



**Curvy White Feather**

DBL77039: 128 per tray



**Curvy Dark Feather**

DBL77038: 128 per tray



**Feather Artisanal**

DBL91250: 126 per tray



**Butterfly**

DBL77918: 120 per tray



**3D White Leaf**

DBL97110: 96 per tray

# Chocolate Decor cont...



**Crisp Pearls Dark**  
CB45Crisp: 1.76 lbs



**Crisp Pearls White**  
CB30Crisp: 1.76 lbs



**Crisp Pearls Milk**  
CBMilkCrisp: 1.76 lbs



**Salted Caramel Pearls**  
CBSCaraCrisp: 1.76 lbs



**MiniMix Crisp Pearls**  
CBMiniMix: 15 oz



**Feuilletine**  
NOE950: 6lbs

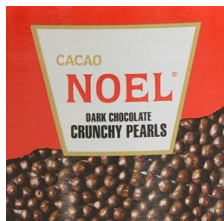

**Dark Crunchy Pearls**  
NOE976: 2.2lbs

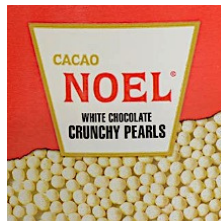

**White Crunchy Pearls**  
NOE975: 2.2lbs



**Dark/White Crunchy Pearls**  
NOE977: 2.2 lbs

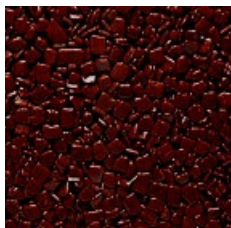

**Semi-Sweet Flakes**  
CBCHFX50: Pallettes 2.2 lbs



**Mocha Coffee Beans**  
NOE981: 3lbs



**Chocolate Coffee Bean**  
CB7484: 2.2 lbs



**Cacao Nibs**  
NOE991: Chocolate Covered 2.2 lbs  
NOE990: Roasted 2.2 lbs

# Chocolate Curls & Shavings



## Colourful Curls



**Dark Blossom Curls**

VDP-6385: 3 lbs

DBL96385: 12 lbs

CB266: Mona Lisa - 10 lbs



**Ivory Blossom Curls**

VDP-6392: 3 lbs

DBL96392: 12 lbs

CB253: Mona Lisa - 10 lbs



**Orange Blossom Curls**

VDP-6398: 3 lbs

DBL96398: 12 lbs



**Pink Blossom Curls**

VDP-6391: 3 lbs

DBL96391: 12 lbs



**Dark/White Blossom Curls**

VDP-6387: 3 lbs

DBL96387: 12 lbs



**Red Blossom Curls**

VDP-6395: 3 lbs

DBL96395: 12 lbs



**Yellow Blossom Curls**

VDP-6394: 3 lbs

DBL96394: 12 lbs



**Dark Spaghetti**

DBL41145: 5.5 lbs



**White Spaghetti**

DBL96335: 5.5 lbs



**Green Blossom Curls**

VDP-6399: 3 lbs

DBL96399: 12 lbs



**Dark Shavings**

DBL96304: 5.5 lbs



**Dark/White Spaghetti**

DBL41119: 5.5 lbs



**Orange Spaghetti**

DBL48218: 5.5 lbs



**White Shavings**

DBL96306: 5.5 lbs

# Chocolate Cups & Shells



**Victoria Cups**  
NOE840: 84 per case



**Pisa Cup**  
DBL11210: 168 per case



**Large Coffee Cup**  
CBCP90099: 36 per case



**Small Coffee Cup**  
CBCP90105: 45 per case



**Assorted Dark Cups**  
CBC90411: 200 per case



**Medium Marbled Tulip Cup**  
CBCP90483: 36 per case



**Petits Four Pastel Tulip Cups**  
CBCP-90368: 152 per case



**Dark Truffle Shells**  
NOE849: 504 per case



**Milk Truffle Shells**  
PA9514: 504 per case



**White Truffle Shells**  
NOE849: 504 per case

# Nut Products

## Nuts

- NU1008:** Whole Blanched Almonds - 7 lbs
- NU1007:** Sliced Blanched Almonds - 7 lbs
- NU1042:** Sliced Blanched Almonds - 25 lbs
- NU1006A:** Diced Blanched Almonds - 7 lbs
- NU1004:** Diced Roasted Hazelnuts - 2.2 lbs
- NU1001:** Whole Blanched Hazelnuts - 7 lbs
- NU1003:** Whole Roasted Hazelnuts - 2.2 lbs
- NU1021:** Hazelnut Crunch - 7.7 lbs
- CBHA5013:** Praline Grains - 2.2 lbs
- MC16082:** Diced Pistachios - 2.2 lbs
- NU1011:** Whole Sicilian Pistachios - 2.2 lbs



## Flours

- NU1009:** Almond Flour - 25 lbs
- NU1009-1:** Almond Flour - 5 lbs
- NU1022:** Blanched Hazelnut Flour - 25 lbs
- NU1005:** Hazelnut Flour Roasted - 2.2 lbs
- NU1050:** Pistachio Flour - 2.2 lbs



## Pastes & Extracts

- CBB79:** Almond Paste - 7 lbs
- CB34BCA:** Almond Marzipan - 8 lbs
- PS4002667:** 50% Hazelnut Paste - 11 lbs
- CB8656:** 100% Hazelnut Paste - 5 kg
- CBGIM-P-1PLAI-LN606:** Gianduja Paste - 5.5 lbs
- MC14024A:** Torrono Nougat Paste - 8.8 lbs
- MC14689:** 100% Pistachio Paste - 8.8 lbs
- GE1015:** 70% Pistachio Paste - 6.6 lbs
- NU2000:** 70 % Pistachio Paste - 2.2 lbs
- NE44249:** Vela 15% Pistachio Paste - 13 lbs



# Fillings, Toppings, Glazes & Gels

## Topfil / Fruitfil

- PS4107137: Apple Wedges - 38 lbs
- PS4107106: Apple Cubes - 38 lbs
- PS4107104: Cherry - 38 lbs
- PS4107133: Guava - 20 lbs
- PS4107241: Raspberry - 38 lbs **\*\*limited stock**
- PS4107109: Strawberry - 38 lbs
- PS4107101: Blueberry - 38 lbs
- PS4107142: Pineapple - 20 lbs



## Cremfil

- PS4107162: Bavarian - 20 lbs
- PS4107163: Silk Bavarian - 38 lbs
- PS4019107: Vanilla Silky Buttercream 24 lbs
- PS4005908: Cheesecake - 20 lbs
- PS4107172: Cream Cheese - 20 lbs
- PS4107170: Golden Lemon - 38 lbs
- PS4107186: Mango Madness - 30 lbs
- PS4107189: Citron Cream - 20 lbs
- PS4107158: Deli Caramel - 20 lbs
- PS4024038: Dulce de Leche - 20 lbs



## Icings & Fondants

- PS4019107: Vanilla Silky Buttercream - 24 lbs
- PS4019219: Shiny White Icing - 43 lbs
- PS4019227: Shiny White Icing - 23 lbs
- FSWHITE20: Satin Ice White Rolled Fondant - 20 lbs
- PS4107551: 80-20 Fondant - 50 lbs
- PS4107822: 90-10 Fondant - 50 lbs



## Mirror Glaze

- PS4102441: Neutre Miroir - 11 lbs
- NOE925: Chocolate Mirror Glaze - 6.6 lbs

## Gels

- HE1006: Apricot Firm Gel - 28.9 lbs
- HE1009: Clear Gel Firm - 27.5 lbs

## Pastry Cream & Custard Fillings

- PA5321: Cold Process Pastry Cream - 33 lbs
- PA5322: Cold Process Pastry Cream - 11 lbs
- PA5326: Hot Process Pastry Cream - 33 lbs
- PS4107843: Cremyvit - 50 lbs
- PS4107218: Finesse Dairy Custard Mix - 25 lbs

## Toppings

- GE1090: Dark Chocolate Topping - 2.64 lbs
- GE1091: Raspberry Topping - 2.64 lbs
- MC24081A: Strawberry Topping - 1 kg



## Glazes

- HE1030: Apricot Glaze - 27.5 lbs
- PS4107187: Harmony Ready Briant BIB - 26.44 lbs
- PS4007202: Sunset Glaze Easy BIB - 20 L
- PS4008689A: Sunset Glaze Easy Carton - 1 L
- PS4008689: Sunset Glaze Easy Carton Case - 12 x 1 L cartons
- PS4107191: Harmony Clear Ready Neutre BIB - 26.44 lbs
- PS4107161: Harmony Classic Briant - 20 lbs
- PS4107190: Harmony Classic Neutre Glaze - 20 lb



## Whipped Topping

- PS4111313A: Ambiente Topping Carton - 1 L
- PS4111313: Ambiente Topping Case - 12 x 1 L cartons
- NE4717A: Creamian Whipping Cream Carton - 1 L
- NE4717: Creamian Whipping Cream Case - 6 x 1 L cartons

# Fruit Products



## Frozen Puree

Available in 1 kg containers or  
case of 5 x 1 kg containers

- RAV981:** Apricot
- RAV861:** Banana
- RAV891:** Blackberry
- RAV821:** Blueberry
- RAV700:** Blood Orange
- RAV961:** Coconut
- RAV802:** Lemon
- RAV804:** Lime
- RAV751:** Lychee
- RAV921:** Mango
- RAV791:** Mandarin Orange
- RAV841:** Morello Cherry
- RAV830:** Pabana
- RAV911:** Passionfruit
- RAV993:** Prickly Pear
- RAV991:** William Pear
- RAV810:** Ruby Peach
- RAV771:** Pineapple
- RAV851:** Pink Guava
- RAV715:** Pomegranate
- RAV901:** Raspberry
- RAV941:** Strawberry
- RAV931:** White Peach

**AMI800:** Yuzu - 2 lbs

**AMI824:** Black Currant - 6 x 1 kg containers per case

## Canned & Jarred

- PA5136A:** Small Whole Pears with Stem Can - 30 oz
- PA5136:** Small Whole Pears with Stem Case 12 x 30 oz cans
- PA2570A:** Mini Sliced Pineapples Can - 20 oz
- PA2570:** Mini Sliced Pineapples Case - 12 x 20 oz cans
- PA4400A:** Apricots in Syrup Can - 4.85 lbs
- PA4400:** Apricots in Syrup Case - 6 x 4.85 lb cans
- AMI450A:** Apple Super Pommies Can - 10 lbs
- AMI450:** Apple Super Pommies Case - 3 x 10 lb cans
- MC26130:** Amarenata Cherries - 6 lbs
- DE5101:** Passionfruit Pearls - 7 oz
- AMI701:** Cherry (Griottes) in Brandy (Pitted) - 1 L
- GE1099:** Whole Amarena Cherries in Syrup - 6.6 lbs



## Frozen Compote

Available in cases of 2 x 5.5 lb containers

- RAV300:** Red Fruits
- RAV301:** Pineapple
- RAV302:** Apricot
- RAV303:** Clementine
- RAV304:** Mango and Passionfruit



## IQF Fruits

Available in cases of 5 x 2.2 lb containers

- RAV985:** Apricot Halves
- RAV840:** Morello Cherries (Pitted)
- RAV990:** Lingonberries
- RAV947:** Summer Fruit



## Zests

Available in 1.12 lb containers

- RAV500:** Orange
- RAV501:** Lemon
- RAV502:** Lime



## Candied Fruit

Available in 2.2 lb containers

- AMI600:** Red Cherries
- AMI615:** Lemon Peel Cubes
- AMI610:** Lemon Peel Strips
- AMI620:** Orange Peel Cubes
- AMI625:** Orange Peel Strips
- AMI626:** Orange Slices



## Bakery Jam

- HE1022:** Raspberry Jam with Seeds - 27.5 lbs
- HE1023:** Raspberry Jam No Seeds - 27.5 lbs
- HE1024:** Apricot Jam - 27.5 lbs
- HE1025:** Strawberry Jam - 27.5 lbs
- HE1026:** Orange Jam - 12.1 lbs

## Shredded

- AMI850:** Fancy Shredded Coconut, Unsweetened
- AMI851:** Desiccated Coconut, Unsweetened



# Flavorings



## Pastes

- AMI710: Banana - 3.3 lbs
- AMI711: Mango - 3.3 lbs
- AMI712: Passionfruit - 3.3 lbs
- AMI713: Raspberry - 3.3 lbs
- AMI714: Strawberry - 3.3 lbs
- AMI716: Lemon - 3.3 lbs
- MC18047A: Strawberry Paste (Fragola) - 6.6 lbs
- MC18080A: Raspberry Paste - 6.6 lbs
- MC14020: Coconut Paste - 6.6 lbs
- MC18082A: Orange Paste - 6.6 lbs
- GE1000: Amarena Cherry Paste - 6.6 lbs
- GE1017: Raspberry Paste - 6.6 lbs



## Essence Oils

- PA8072: Orange Essence Oil - 16.9 oz
- PA8070: Lemon Essence Oil - 16.9 oz

## Extracts

- GA200: Pure Almond Extract - 16.9 oz
- GA205: Pure Lemon Extract - 16.9 oz
- GA206: Pure Orange Extract - 16.9oz
- GA207: Pure Peppermint Extract - 16.9 oz
- TR5000: Trablit Coffee Extract - 32 oz



## Waters

- IFC441-17: Orange Blossom Water - 17 oz
- IFC441-10: Orange Blossom Water - 10 oz
- IFC604-17: Rose Water - 17 oz
- IFC604-10: Rose Water - 10 oz



## Vanillas

- T107: Vanilla Extract - 1 gal
- T106: Vanilla Extract - 32 oz
- T104: Vanilla Paste - 16 oz
- T105: Vanilla Beans - 8 oz
- NVNP2: Vanilla Bean Powder - 2 oz

## Flavored Alcohol & Sugar Shards

- GC001A: Caramelized Sugar Shards - 1125 g
- GC001: Caramel Alcohol Spray - 16 oz
- GC0011: Oregano Flambe Gel - 16 oz
- GC0012: Chili Pepper Flambe Gel - 16 oz
- GC0013: Cointreau Alcohol Spray - 16 oz
- GC0015: Caramel Flambe Gel - 16 oz





# Mixes

## Bread Mixes

- PS4107529:** Easy Soft'r Potato Roll - 50 lbs
- PS4107265:** Easy San Fransisco Sourdough Mix - 50 lbs
- PS4107268:** Easy Pumpernickel Base - 50 lbs
- PS4014453:** Softgrain Multigrain CL - 38 lbs



## Cake Mixes



- PS4011846:** White Layer CL Fine Cake Mix - 50 lbs
- PS4014073:** Satin CL Plant-Based Cake Mix - 50 lbs
- PS4107217:** Genoise Sponge Cake Mix - 50 lbs
- PS4107219:** Satin Creme Cake Mix - 50 lbs
- PS4107220:** Chocolate Satin Creme Cake Mix - 50 lbs
- PS4107325:** Satin Devil's Food Layer Mix - 50 lbs
- PS4107326:** Satin White Layer Cake Mix - 50 lbs
- PS4107331:** Satin Supreme Creme Cake Mix - 50 lbs
- PS4107370:** Satin Red Velvet Layer Cake Mix - 50 lbs
- PS4107584:** Cakey Brownie Cake Mix - 50 lbs
- PA5309:** Gluten Free Genoise Sponge Cake Mix - 11 lbs
- PA5311:** Vegan Genoise Sponge Cake Mix - 11 lbs



## Mousse Mixes



- PS4107486:** One Step Neutral/Vanilla Mousse - 25 lbs
- NOE352A:** White Chocolate Mousse Mix Bag - 2.2 lbs
- NOE352:** White Chocolate Mousse Mix Case - 5 x 2.2 lb bags
- NOE350A:** Chocolate Mousse Mix Bag - 2.2 lbs
- NOE350:** Chocolate Mousse Mix Case - 5 x 2.2 lb bags
- SC8090029A:** White Chocolate Mousse Mix #10 can - 5 lbs
- SC8090029:** White Chocolate Mousse Mix Case - 6 x 5 lb cans

## Miscellaneous

- PA5345A:** Crème Brûlée Mix Bag - 2.2 lbs
- PA5345:** Crème Brûlée Mix Case - 5 x 2.2 lb bags
- PA5351:** Meringue Mix - 10 lbs
- PS4107606:** Gourmet Brownie Mix - 50 lbs
- PA5350:** Pate a Choux Mix Case - 5 x 2 lb bags
- PS4107597:** Coconut Macaroon Cookie Mix - 25 lbs



# Colorings



Don't see a color you need listed? Ask us about special ordering.  
Lead time 1 - 2 weeks.

## Colored Cocoa Butter

Available in 7 oz containers

- CR302001C: Alabaster White
- CR302155C: Eclipse Black
- CR302005C: Aureolin Yellow
- CR302115C: Cardinal Red
- CR302060C: Jade Green
- CR302065C: Regal Blue
- CR302025C: Sunrise Orange
- CR302145C: Tuscan Brown
- CR302097C: Purple Heart
- CR302110C: Passion Pink
- CR302104C: Oh My Magenta *\*\*limited stock*
- CR302050C: Key West Green
- CR302330C: Gold



## Decor Powder

Available in 50 g containers

- CR313013E: Silver
- CR314015E: Super Gold
- CR314001E: Antique Gold
- CR314007E: Cosmic Pink



## Fat Dispersible Powder

Available in 50 g containers

- CR306001E: White - 100 g
- CR306037E: Black
- CR306005E: Yellow
- CR306013E: Green
- CR306009E: Orange
- CR306025E: Red
- CR306017E: Royal Blue
- CR306023E: Purple
- CR306025B: Red - 2.2 lbs *\*\*limited stock*
- CR306025C: Red 1.1 lbs *\*\*limited stock*



## Color for Macarons

Available in 50 g containers

- CR309029E: Burgundy *\*\*limited stock*
- CR3309049E: Black *\*\*limited stock*

## Pearl Powder

Available in 50 g containers

- CR312006E: Red
- CR312002E: Gold

## Emulsion Gels

Available in 8.8 oz containers

- CR303401B: White
- CR303460B: Black
- CR303441B: Pink
- CR303435B: Purple
- CR303445B: Red
- CR303418B: Green
- CR303412B: Orange
- CR303406B: Yellow
- CR303427B: Royal Blue
- CR303453B: Brown
- CR303455B: Chocolate Brown *\*\*limited stock*



## Edible Glitter

Available in 113 g containers

- CR4030012B: Gold Metallic
- CR403013B: Silver
- CR403009B: Green
- CR403003B: Blue
- CR403005B: Clear
- CR403019B: Red
- CR403001B: Amethyst
- CR403002B: Yellow

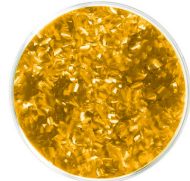

## Water Soluble Powder

Available in 50 g containers

- CR307001E: White - 100 g
- CR307053E: Black
- CR307009E: Orange
- CR307045E: Red
- CR307005E: Yellow
- CR307025E: Cobalt Blue
- CR30721E: Royal Blue
- CR307013E: Green
- CR307029E: Purple



## Flashy Sparkles

Available in 50 g containers

- CR315201B: Red
- CR315206B: Green
- CR315219B: Silver
- CR315212B: Sapphire Blue



# Finishing Touches

## Sugars

For more technical sugars, please see Technical Ingredients



- PA5378:** Snow Sugar - 11 lbs
- WS711SS:** White Sanding Sugar - 10 lbs
- WS711SSRed:** Red Sanding Sugar - 2 lbs
- WS711SSGreen:** Green Sanding Sugar - 2 lbs
- CR3401050C:** Pearl Red Crystal Sugar - 31.75 oz
- CR401051C:** Pearl Baby Blue Crystal Sugar - 31.75 oz
- CR401056C:** Pearl Green Crystal Sugar - 31.75 oz
- CR401059C:** Pearl Lavender Crystal Sugar - 31.75 oz
- CR401061C:** Pearl Pink Crystal Sugar - 31.75 oz
- CR401063C:** Pearl White Crystal Sugar - 31.75 oz
- WR10250:** Pretzel Salt - 10 lbs

## 24 K Edible Gold Leaf & Silver

- COR-EGL:** Gold Leaf Booklet - 25 sheets
- COR-ESL:** Silver Leaf Booklet - 25 sheets
- COR-EGLFJ:** Gold Leaf Flakes - .001 g
- COR-EGLCS:** Gold Leaf Crumbs Shaker - .001 g



## Sprays

**PA9833:** Silver Dust Spray - 4.75 oz *\*\*limited stock*

- LCV200:** White Velvet Spray - 400 mL
- LCV001:** Orange Velvet Spray - 400 mL
- LCV002:** Purple Velvet Spray - 400 mL
- LCV003:** Sky Blue Velvet Spray - 400 mL
- LCV004:** Lilac Velvet Spray - 400 mL
- LCV209:** Green Velvet Spray - 400 mL
- LCV204:** Yellow Velvet Spray - 400 mL
- LCV208:** Red Velvet Spray - 400 mL
- LCV207:** Pink Velvet Spray - 400 mL
- LCV015:** Dark Chocolate Velvet Spray - 400 mL
- LCV105:** Milk Chocolate Velvet Spray - 400 mL



- BDLS692:** Pink Luster Spray - 13.5 oz
- BDLS693:** Blue Luster Spray - 13.5 oz
- BDLS694:** Gold Luster Spray - 13.5 oz
- BDLS699:** Silver Luster Spray - 13.5 oz
- BDLS690:** Red Luster Spray - 13.5 oz
- BDLS691:** Green Luster Spray - 13.5 oz

# Technical Ingredients

## Improvers

- PS4018680:** Intens Fresh 2-30 - 50 lbs
- PS4107254:** S-500 Red - 50 lbs
- PS4100276-1:** O-Tentic Durum Bag: 2.2 lbs
- PS4100276:** O-Tentic Durum Case: 10 x 2.2 lb bags
- PS4107199:** Sapore Fidelio BIB - 22 lbs
- RD59092A:** Red Yeast Instant SAF Block - 1 lb
- RD59092:** Red Yeast Instant SAF Case - 12 x 1lb blocks
- RD59108A:** Gold Yeast Instant SAF Block - 1 lb
- RD59108:** Gold Yeast Instant SAF Case - 12 x 1 lb blocks

## Emulsifiers

- CT1051:** Ultra-Tex 3 Tapioca Starch - 1 lb
- CT1029:** Ultra-Tex 8 Tapioca Starch - 1 lb
- CT1033:** Versawhip - 1 lb

## Stabilizers

- CT1075:** Aero Whipped Cream Stabilizer Powder - 1 lb
- CT1055:** Liquid Whipped Cream Stabilizer - 33.8 oz
- CT1093:** Uno Stabilizer Hot & Cold Process - 1 lb
- CT1030:** Tapioca Maltodextrin - 1 lb

## Sugars & Syrups

- PA0100:** Decomalt / Isomalt - 15 lbs
- PA6514:** Glucose Powder - 11 lbs
- PA6592:** Glucose Syrup - 11 lbs
- PA6089:** Nevuline Trimoline - 15.5 lbs
- PA6250:** Sugar Grains 10 Calibre - 10 lbs
- PA6251:** Sugar Grains Medium 6 Calibre - 10 lbs
- CT1006:** Dextrose - 8 lbs
- CT1009:** Sorbitol Powder - 1 lb
- CR501404C:** Maltitol Powder - 2.2 lbs
- WL1031:** Whey Low Brown Sugar - 5 lbs
- WL1028:** Whey Low Granular White Sugar - 5 lbs

## Butter & Margarine

- BUE275:** Beurremont Dry Butter Sheets 82% - 10 x 2.2 lb sheets
- PS4107865:** Aloha Danes Margarine - 22 lbs

## Shortening & Oils

- PS6102478:** Nutex Liquid Vegetable Shortening - 38 lbs
- DF2396316:** Sweetex Shortening - 50 lbs



## Gelifiers

- CR501418D:** Pectin (NH) Glazing - 2.2 lbs
- CR501420C:** Pectin (Low-Sugar) Glazing - 2.2 lbs
- RD69622:** Knox Gelatin Powder - 1 lb
- CT1000:** Sodium Alginate - 1 lb
- CT1001:** Kappa Carrageenan - 1 lb
- CT1018:** Iota Carrageenan - 1 lb
- CT1019:** Agar Powder - 1 lb
- CT1012:** Apple Pectin - 1 lb
- CT1013:** Thermo-Reversible Pectin - 1 lb
- CT1027:** Pectin PDF 2x "Vitpris" Double Strength - 1 lb
- CT1056:** Fish Gelatin - 1 lb
- CT1032:** Gelatin Powder (225 Bloom) - 1 lb
- PA0400:** Silver Gelatin Sheets - 400 sheets
- PA0402:** Bronze Gelatin Sheets - 300 sheets
- PA0404:** Gold Gelatin Sheets - 500 sheets
- PA5344:** Quick-Gel Plus - 5.5 lbs



## Gums

- CT1017:** Xanthan Gum - 1 lb
- CT1025:** Gellan Gum Low Acyl - 1 lb

## Acids

- CT1005:** Tartaric Acid - 1 lb
- CT1007:** Citric Acid - 1 lb
- CT1031:** Ascorbic Acid - 1 lb



## More Technical Ingredients

- CT1077:** Whole Egg Replacer - 1 lb
- CT1054:** Egg White Powder - 1 lb
- CR501609B:** Sodium Hydroxide (Lye) Unit - 2 lbs
- CR501609:** Sodium Hydroxide (Lye) Case - 25 lbs



**cuisine-tech**



# Savory



**Olive Oil Extra Virgin**  
ESP255: 33.8 oz



**Five Spice Powder Pilar**  
SP1404: 12oz

*\*\*limited stock*



**Black Truffle infused Olive Oil**  
SCAAL520: 8.3 oz

*\*\*limited stock*



*\*\*limited stock*

**Black Summer Truffle Peelings**  
GO1502: 7 oz



**Swissco Shrimp Base**  
SCA8090014A: 16oz  
SCA8090014: 6 x 16 oz cans per case



**Pomodorino Sauce**  
SCA055911: 5lbs



**Espagnole Sauce**  
SC8000602: 32 oz



**Chicken Flavored Stock**  
SC8000723A: 32 oz  
SC8000723: 6 x 32 oz cans per case



**Supreme Chicken Paste**  
SC8000441: 32 oz



**Supreme Beef Base**  
SC8000419: 32 oz



**Bechamel White Sauce**  
SC8000609: 32 oz

# Tools



## 21" Piping Bags

PS42491: 100 per case



## Lollipop Sticks

FS5720: 4" - 100 per bundle  
FS5721: 6" - 100 per bundle



## 12" Disposable Piping Bags

FS4712: 100 per case



## Freeze Spray

CR703003A: 1 can - 15 oz  
CR703003: Case - 12 x 15 oz cans



## Quick Blow Canned Air

CR703001B: Can - 12 oz



## Edible Frosting Sheets

AM954416: 8 x 11" - 24 per package



*\*\*limited stock*

## Mini Square Dish

CR207001B: 2.25" x 2.25" x .5" - 250 per case

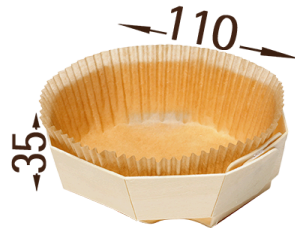

*\*\*limited stock*

## Wooden Baking Pans

PB110: Panibois Octopuce - 400 per case

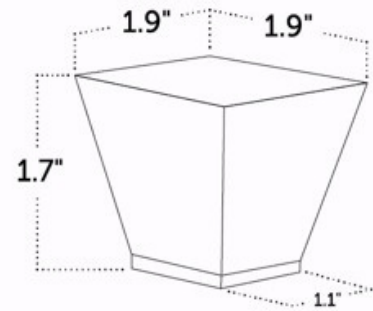

## Sleek Tapered Cup

CR205002A: 1" x 1.7" x .2.1" - 576 per case

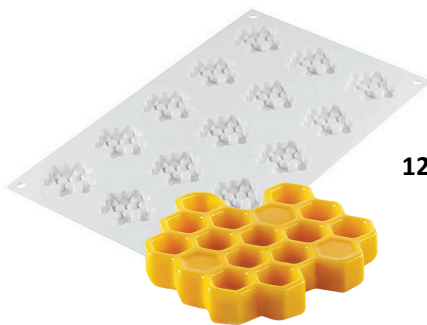

## "Miel 8" Silicone Honeycomb Mold

12345: Cavity Size - 1.8: x 0.31  
1 mold per container

*\*\*limited stock*

## Acetate Plastic Rolls

Available in 5 mil thickness and 1,000 ft length

CR707003: 1.75" width  
CR707007: 2" width  
CR707005: 2.375" width  
CR707009: 3.5" - width



PCB220: Guitare Acetate Sheets: 16" x 24" - 100 per box



